

SINGLE-PHASE CONNECTIONS (ONE-ELEMENT)

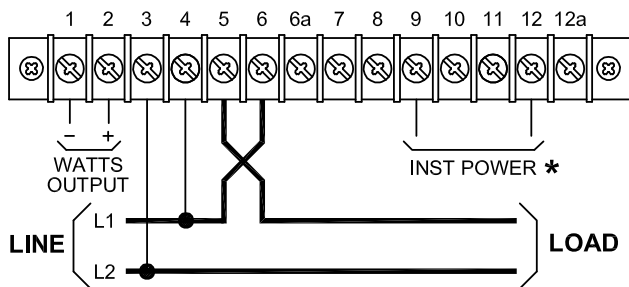

DIRECT CONNECTION

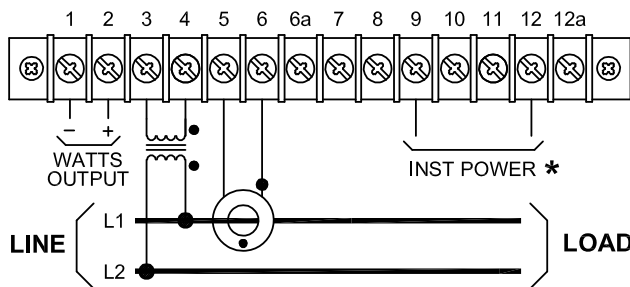

USING POTENTIAL AND CURRENT TRANSFORMERS

THREE-PHASE, THREE-WIRE CONNECTIONS (TWO-ELEMENT)

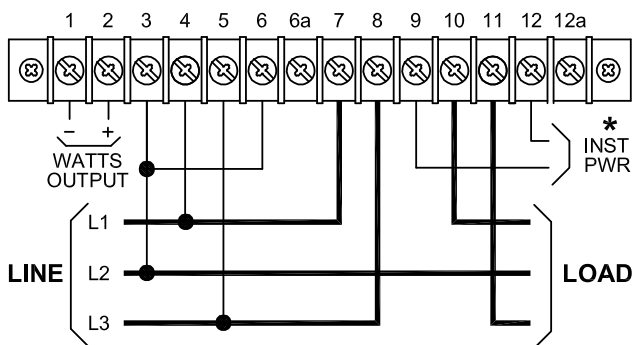

DIRECT CONNECTION

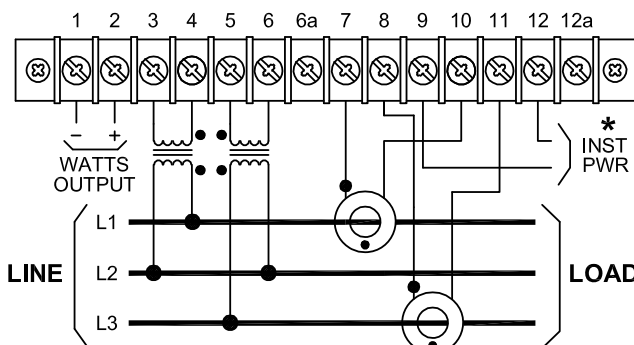

USING POTENTIAL AND CURRENT TRANSFORMERS

THREE-PHASE, FOUR-WIRE CONNECTIONS (2-1/2 ELEMENT)

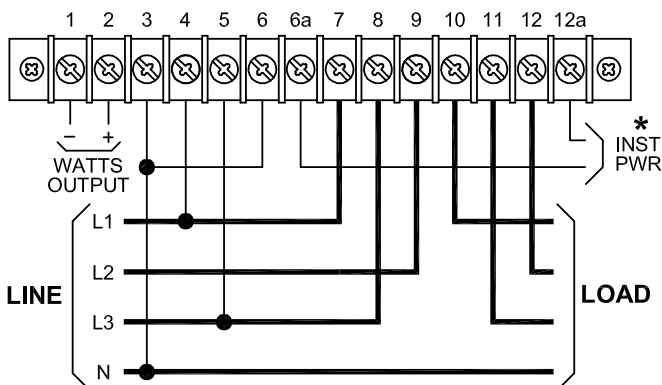

DIRECT CONNECTION

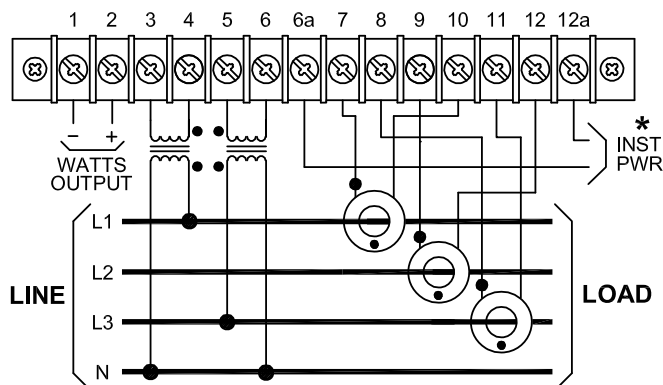

USING POTENTIAL AND CURRENT TRANSFORMERS

Dwg# 0902-00877-B Rev --

THREE-PHASE, FOUR-WIRE CONNECTIONS (THREE-ELEMENT)

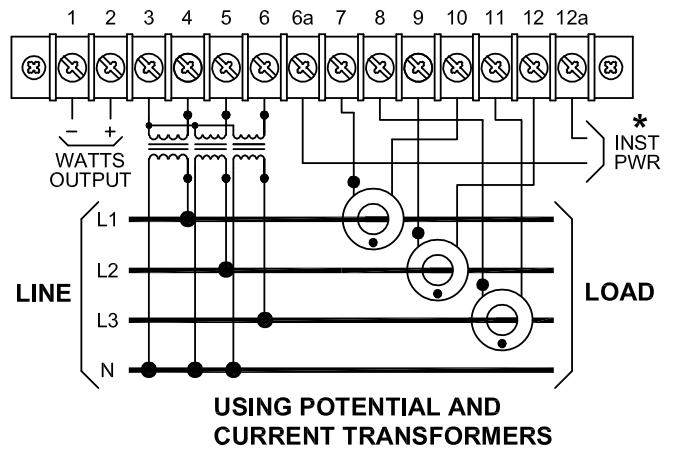
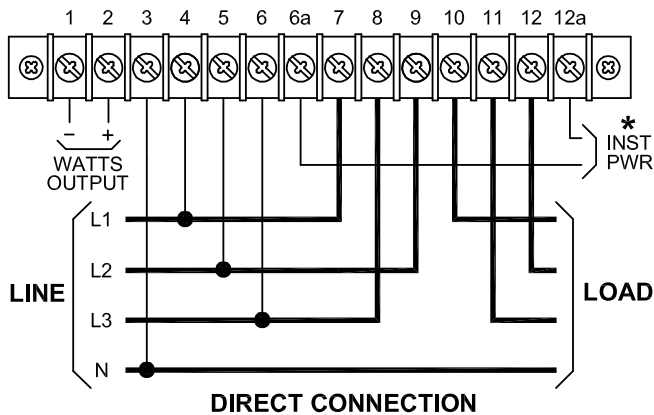

* Instrument Power for all models is 115V ±15%, 60Hz, 7.5VA

WATTHOUR OUTPUT CONNECTIONS

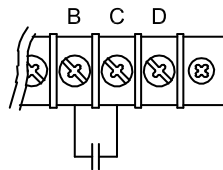

**STANDARD OUTPUT
SPST RELAY**

CASE DIMENSIONS

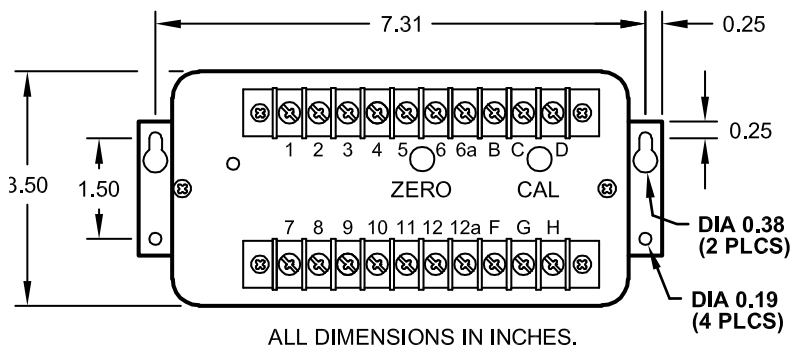

CASE HEIGHT 5.88"
1PH 2W 2.9 LBS
3PH 3W 3.3 LBS
3PH 4W 3.8 LBS

ALL DIMENSIONS IN INCHES.

Dwg# 0902-00877-B Rev--